

Montageanleitung
 MA_STS_PLANEО X_silent
 Art.-Nummer: 480 06 02 00



PLANEО X
 Safety-Advices, Care instructions,
 service and maintenance



M0000126

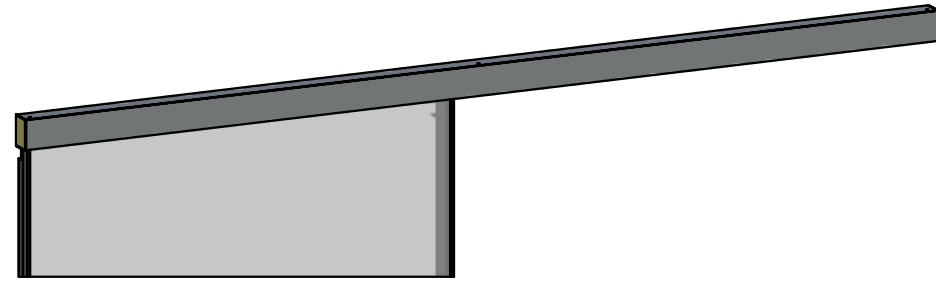

PLANEО
 X

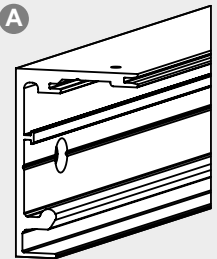

1x

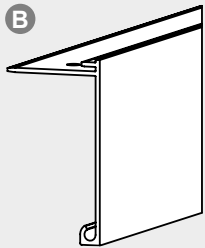

1x

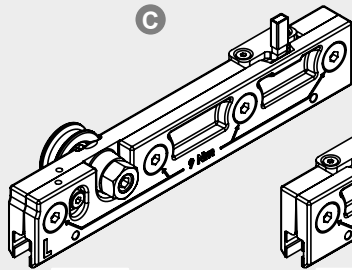

1x

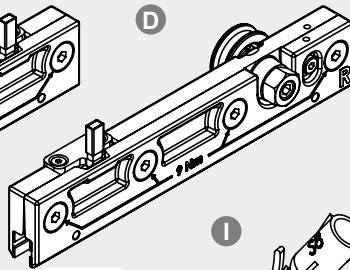

1x



8x40

8x

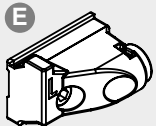

1x

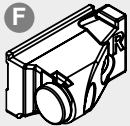

1x

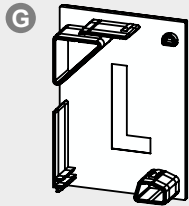

1x

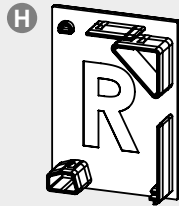

1x

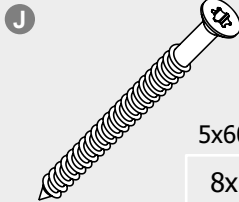

5x60

8x

Comfort

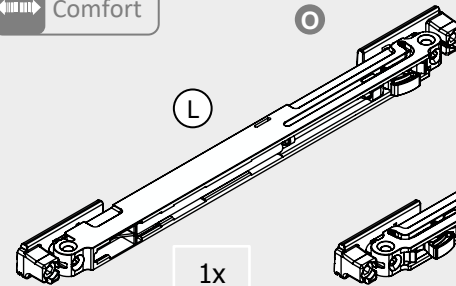

1x

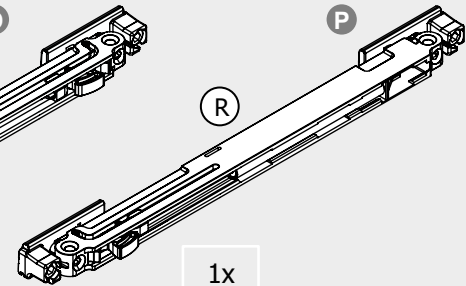

1x

~~non Comfort~~

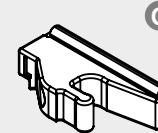

1x

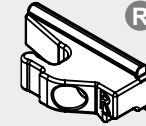

1x

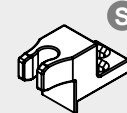

2x



M3x8

4x

Wird nicht benötigt / not required

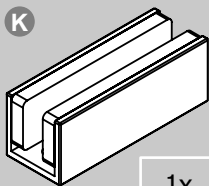

1x

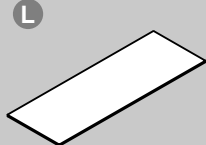

1x

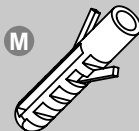

6x30

2x

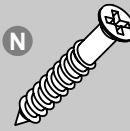

4x30

2x

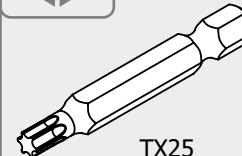

TX25

1x

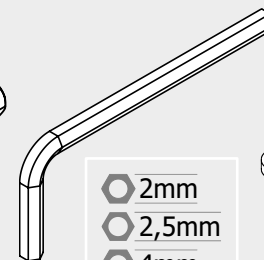

2mm
 2,5mm
 4mm

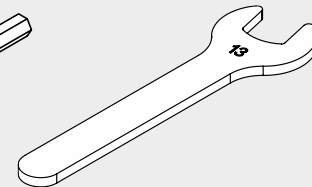

1x

SCHIEBETÜRSYSTEM PLANEО X - AIR silent



**AIR
SILENT**

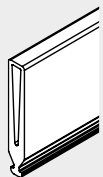

1x

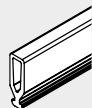

1x

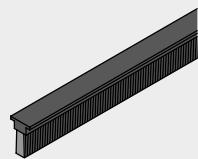

1x

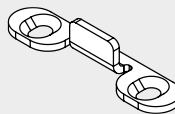

1x



1x

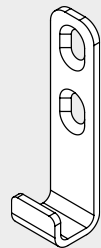

1x

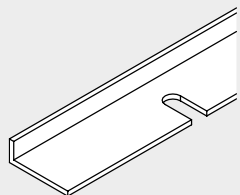

1x

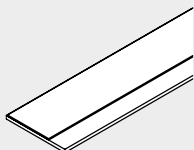

1x



6x30

8x



4,2x33

6x

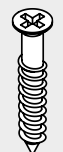

4x30

2x



11,5x5

6x



8x



Wand* / wall*



∅ 6mm
∅ 8mm

Metall / metal

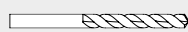

∅ 6mm

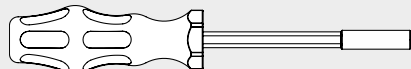
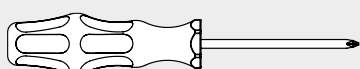

1/4" (6,35mm)

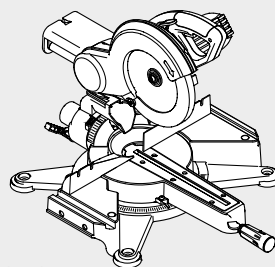
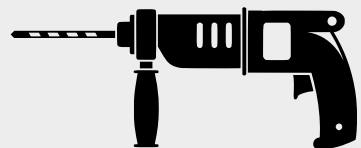

*Bohrer entsprechend Untergrund wählen / *select a drill according to the substrate



non Comfort

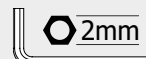
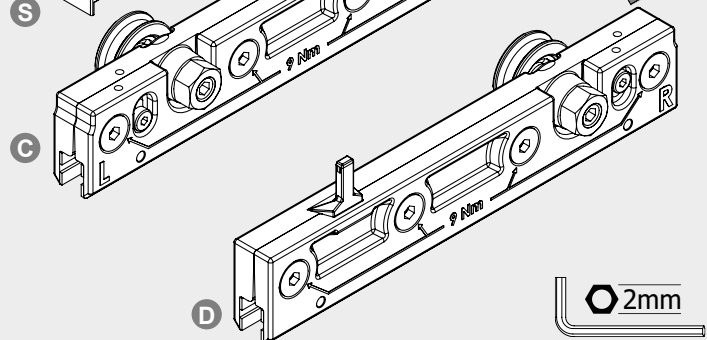
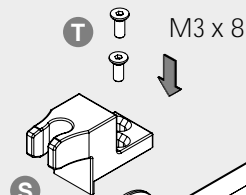

SCHIEBETÜRSYSTEM PLANEО X - AIR silent

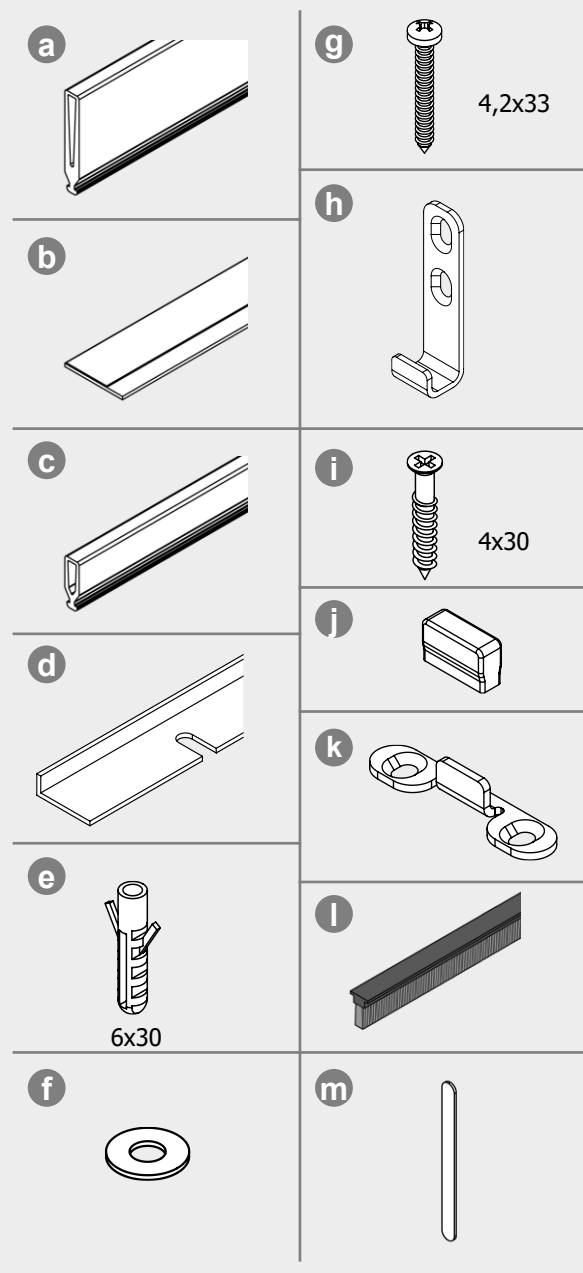
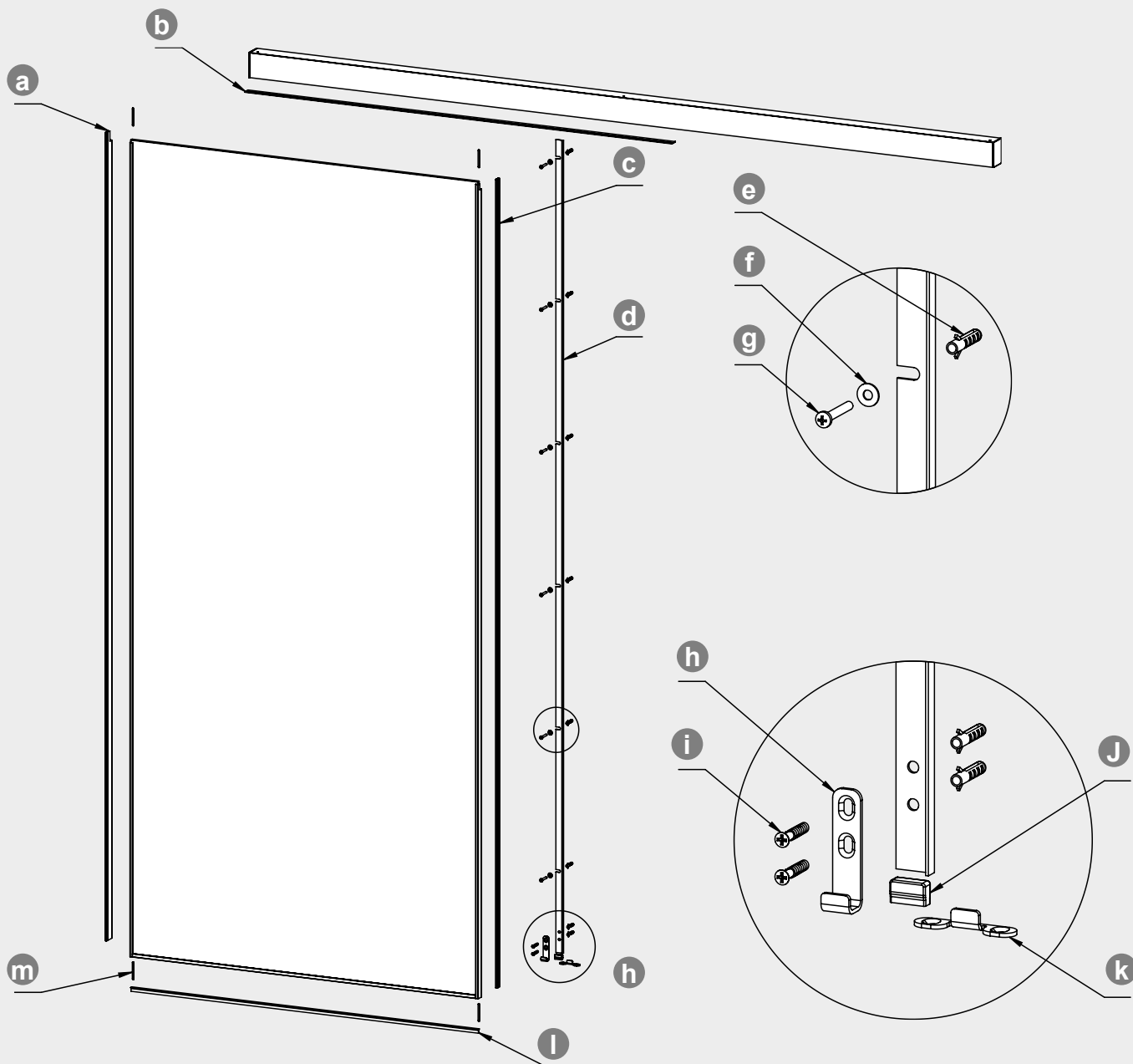

SCHIEBETÜRSYSTEM PLANEО X - AIR silent

Auswahl Bodenführung / floor guide selection

Wählen Sie die Bodenführung anhand der gegebenen Sockelausbildung, und beachten Sie die entsprechenden Hinweise in den Montageschritten /
 Select the floor guide on the basis of the given plinth design and follow the corresponding instructions in the installation steps

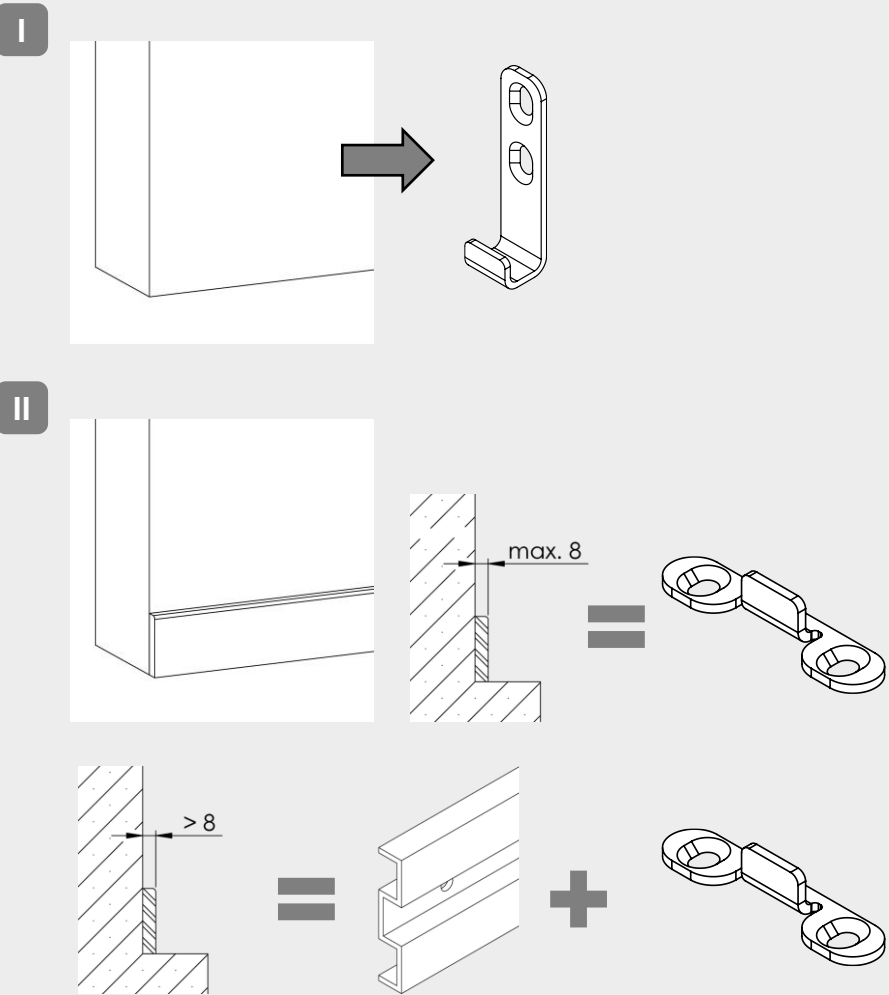

Vorbereiten Bodenführung / preparing the floor guide

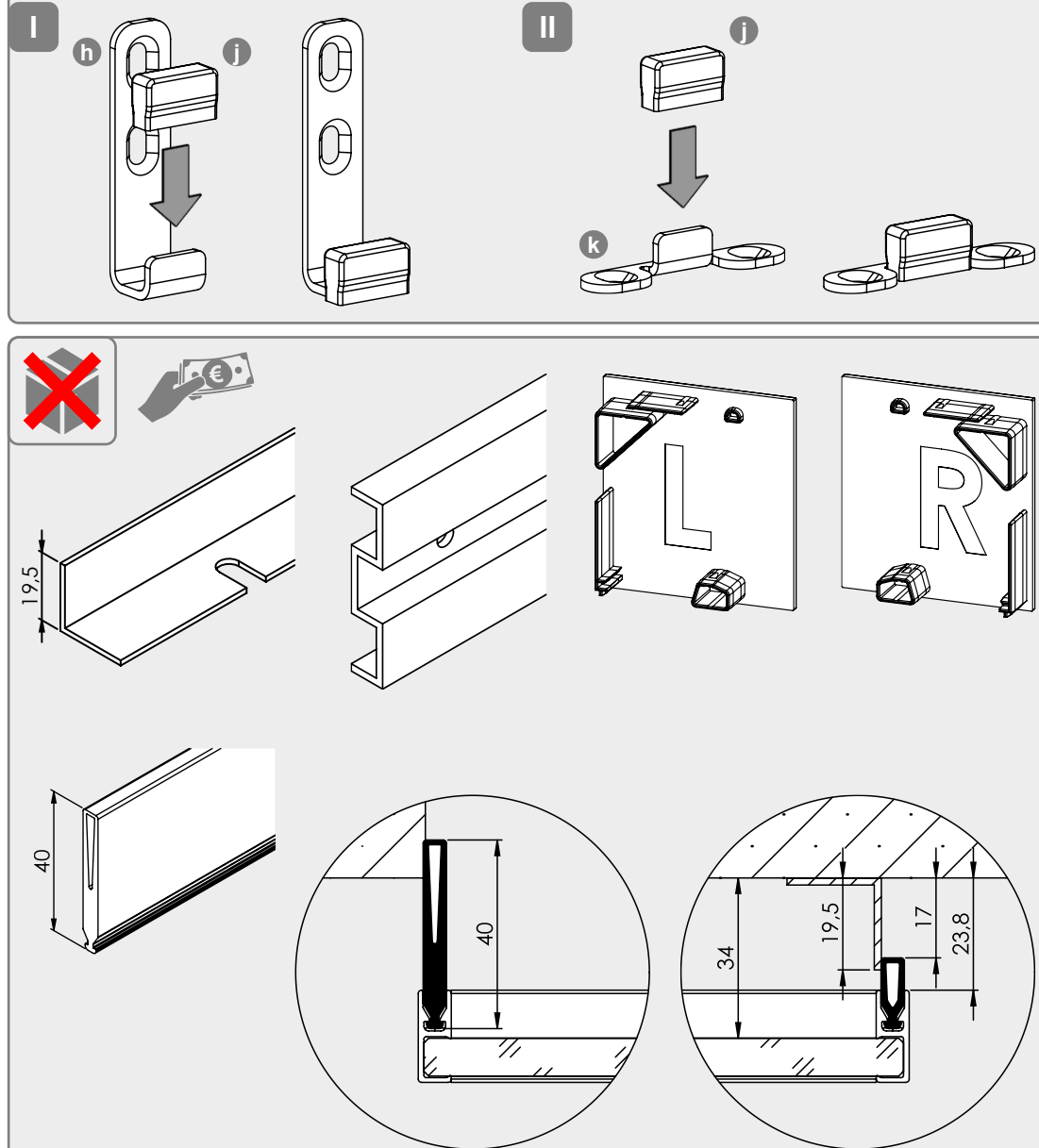

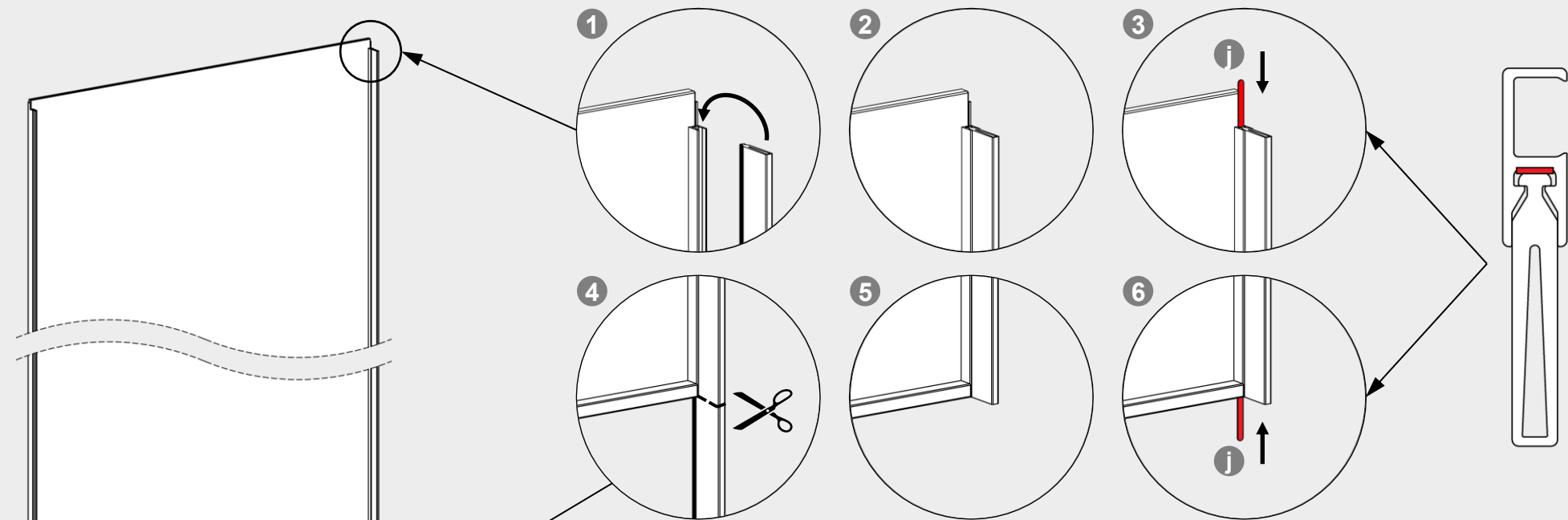

Diese Montageanleitung zeigt eine nach rechts öffnende Türe, bei einer nach Links öffnenden Türe erfolgt die Montage der Dichtprofile gespiegelt
These installation instructions show a door that opens to the right, with a door that opens to the left, the installation of the sealing profiles is mirrored

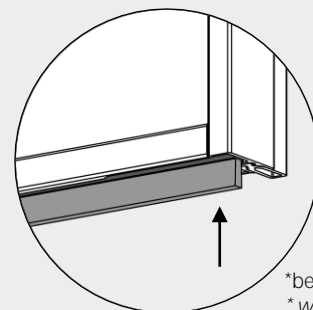
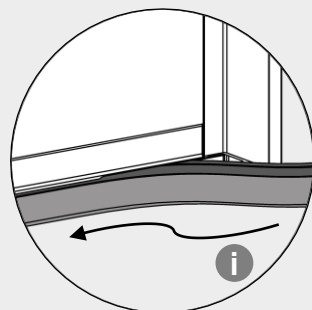
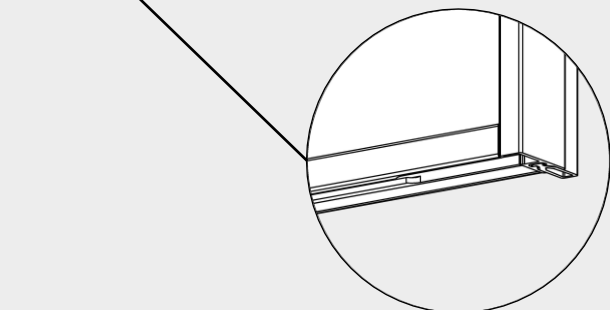

Profil Griffseite*
 profile handle side*

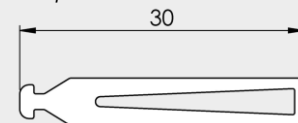

Profil Wandseite
 profile wall side

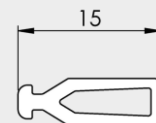

*bei Verwendung eines Distanzprofils, dass dem Set beiliegende Profil verwenden /
 * when using a spacer profile, use the profile supplied with the set

SCHIEBETÜRSYSTEM PLANEО X - AIR silent

Montage Laufwagen / mounting rollers

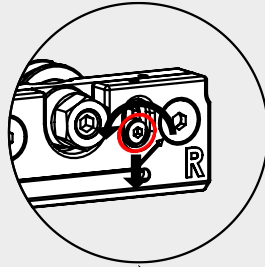
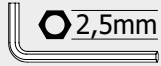
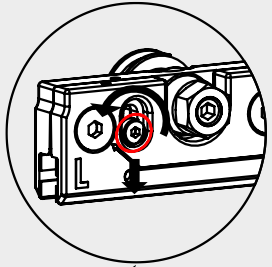
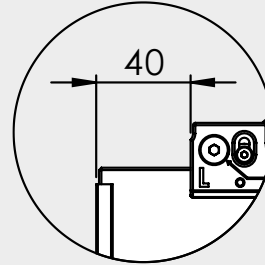
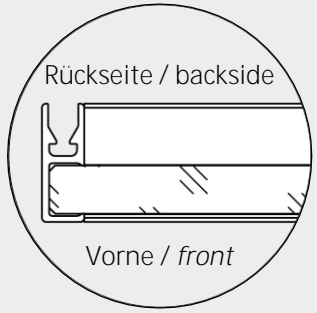

Schraube der Aushängesicherung lösen und nach unten schieben /
loosen the screw of the safety catch slightly and slide it downwards.

D

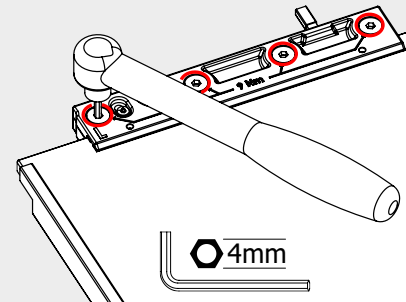
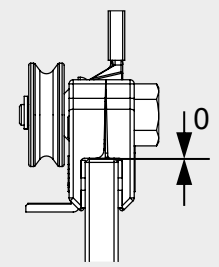
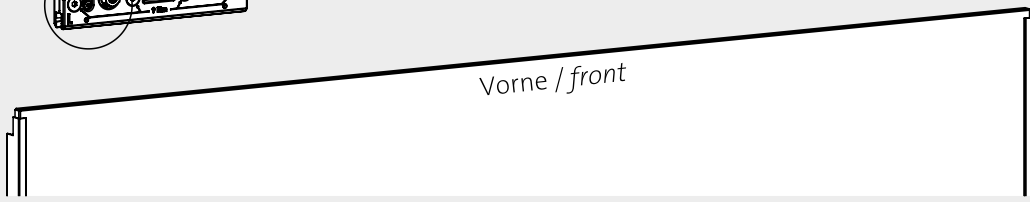
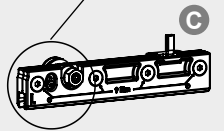
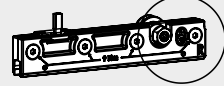

60	9 Nm	80	10 Nm	120	8 Nm

SCHIEBETÜRSYSTEM PLANEО X - AIR silent

Wandbefestigung / Wall-mounting

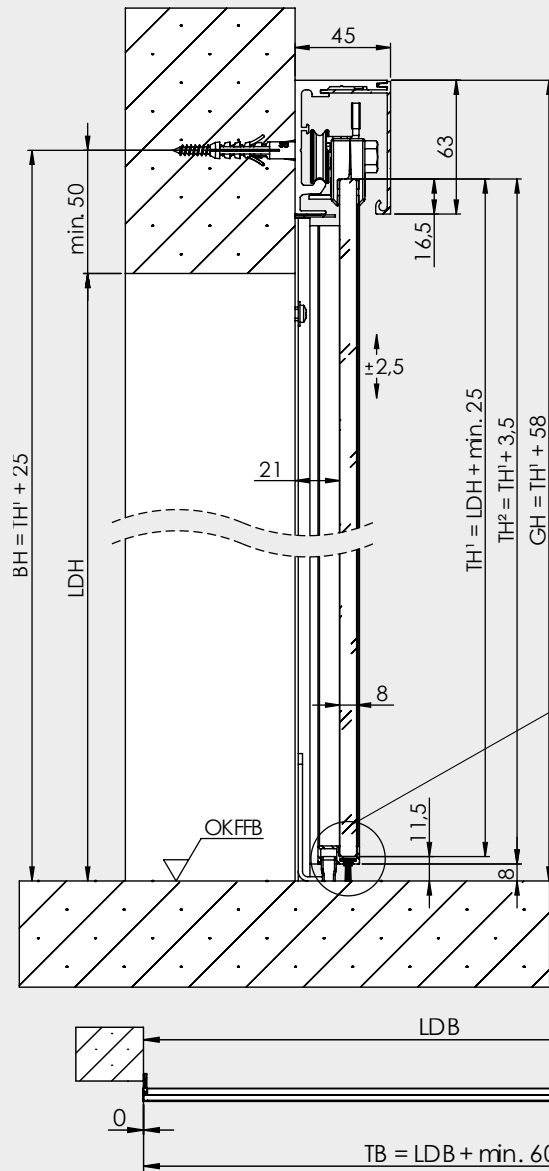

- GH = Gesamthöhe / total height
- TH¹ = Glashöhe / glass height
- TH² = Türhöhe mit Rahmen / door height with frame
- TB = Türbreite / door width
- BH = Bohrhöhe / drilling level
- LDH = Lichte Durchgangshöhe / pass line height
- LDB = Lichte Durchgangsbreite / pass line width



Abbildung nicht maßstabsgetreu / illustration not to scale



*Bohrer entsprechend Untergrund wählen / * select a drill according to the substrate

SCHIEBETÜRSYSTEM PLANEО X - AIR silent

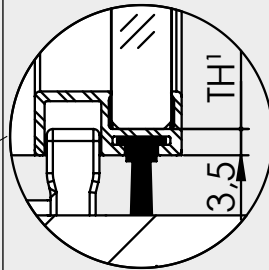
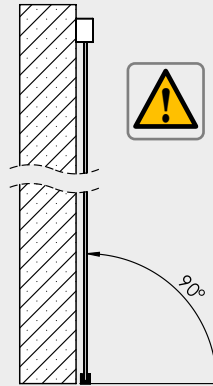
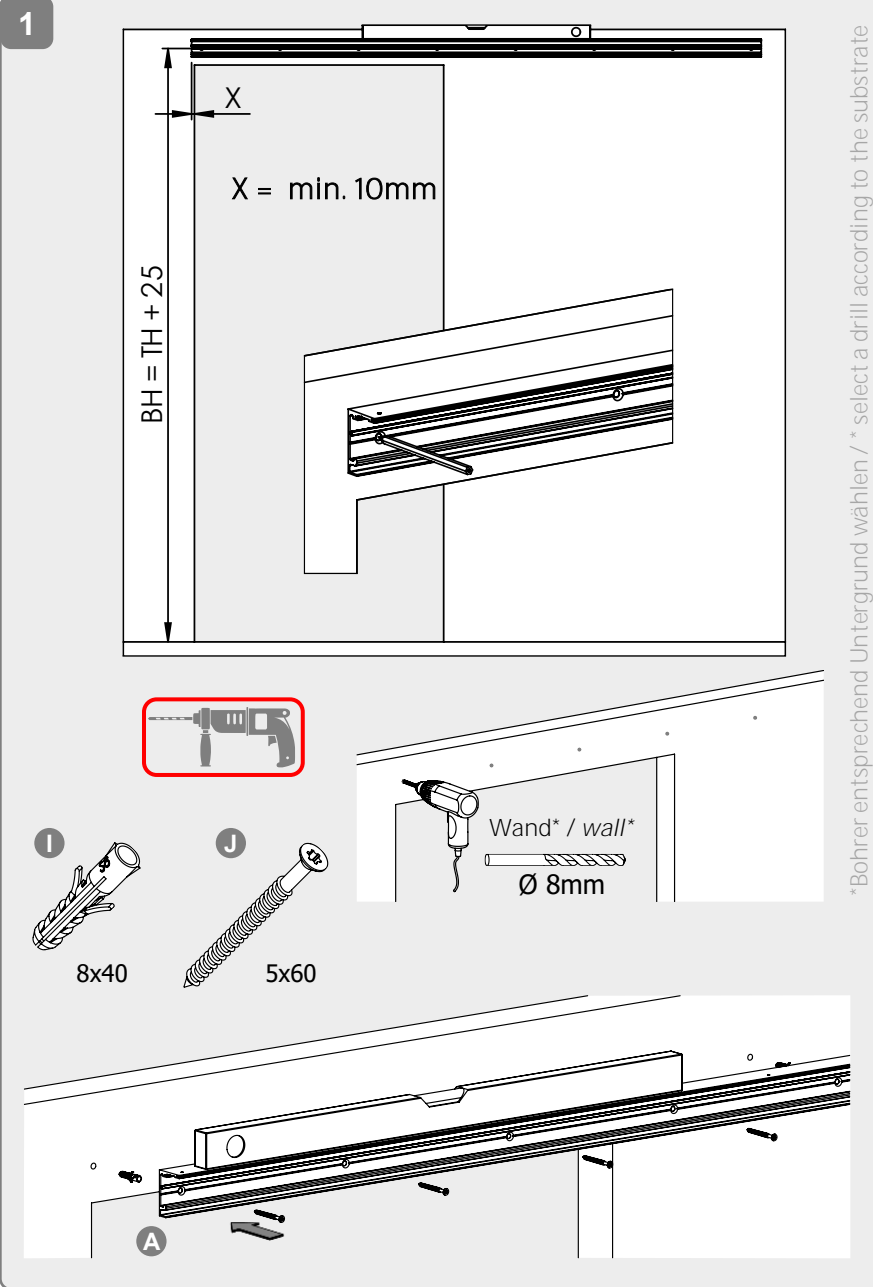
2

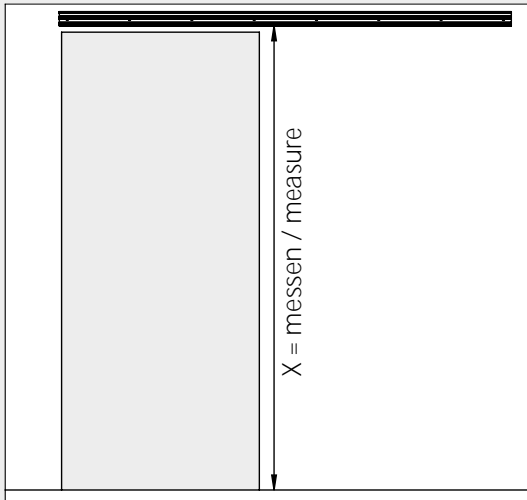

Beim Anreißen und Ablängen bitte darauf achten, dass der kürzere Schenkel nach außen zeigt, und der kurze Bohrabstand zur Laufschiene zeigt / when marking and cutting to length, make sure, that the shorter side points outwards, and that the short drill distance points towards the rail

$$Y = X - 2\text{mm}$$

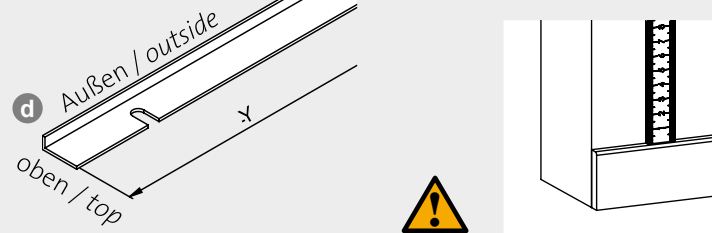

Wenn eine Sockelleiste vorhanden ist, bis auf deren Oberkante messen / If a baseboard is present, measure up to its upper edge

2a



Nur bei Verwendung Bodenführung Wand / only when using floor guide Wall

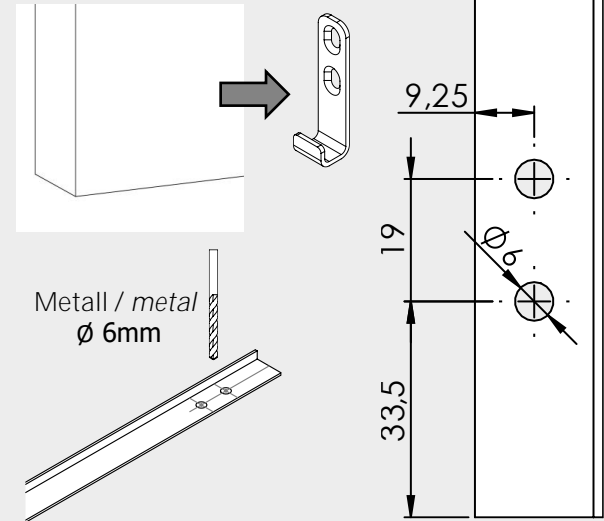

*bei Verwendung eines Distanzprofil-Set, dass dem Set beiliegende Profil verwenden / *when using a spacer profile set, use the profile supplied with the set

3

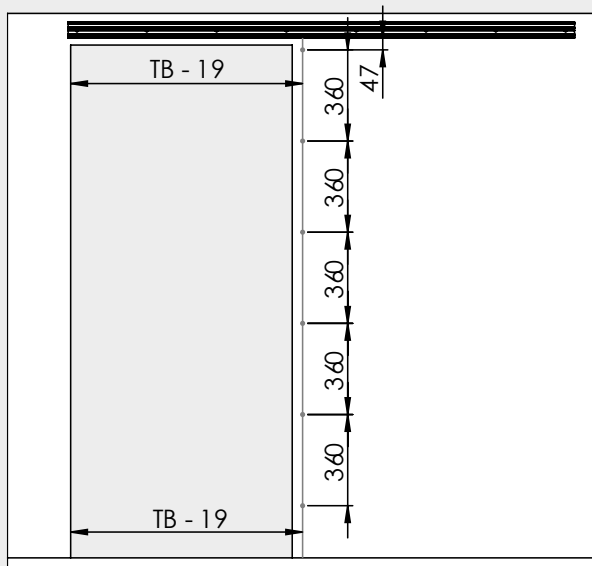

1

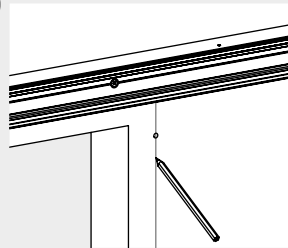

2

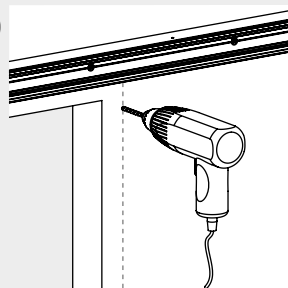

3

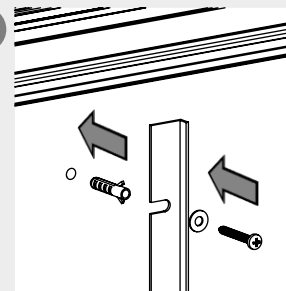

Wand* / wall*
Ø 6mm

*Bohrer entsprechend Untergrund wählen / *select a drill according to the substrate

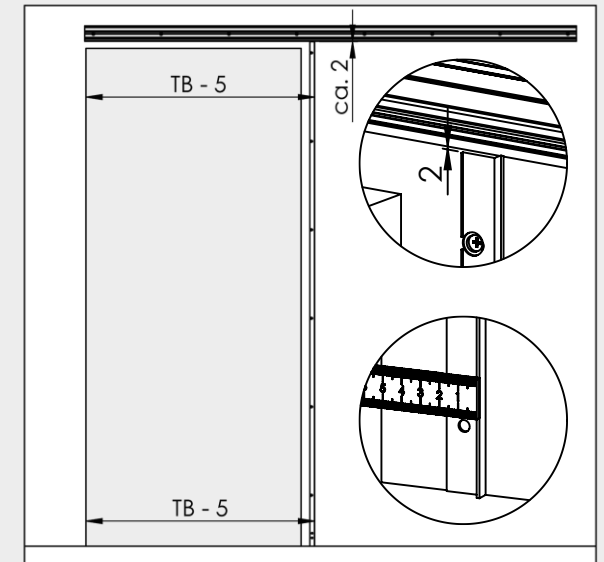

SCHIEBETÜRSYSTEM PLANEО X - AIR silent

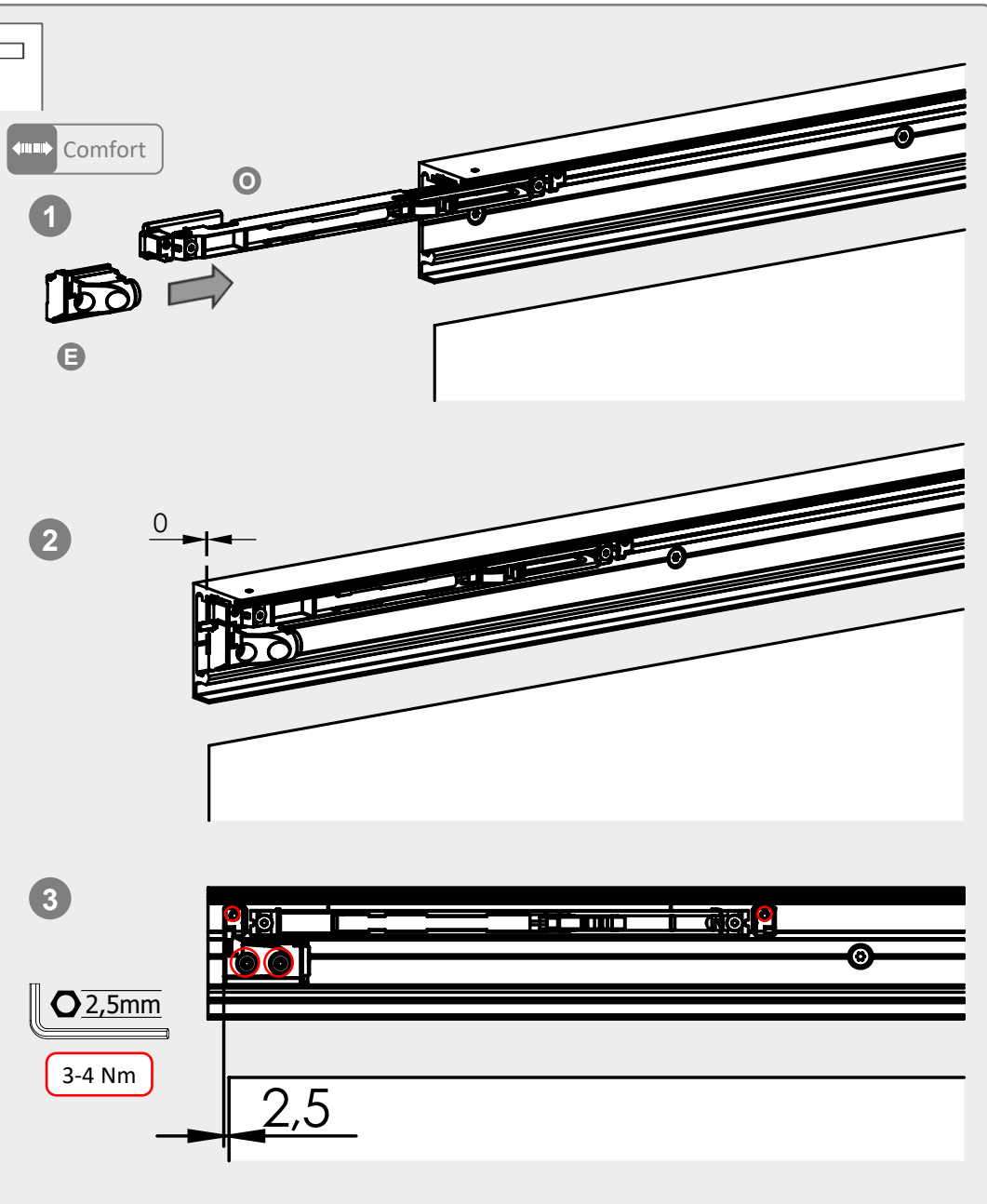
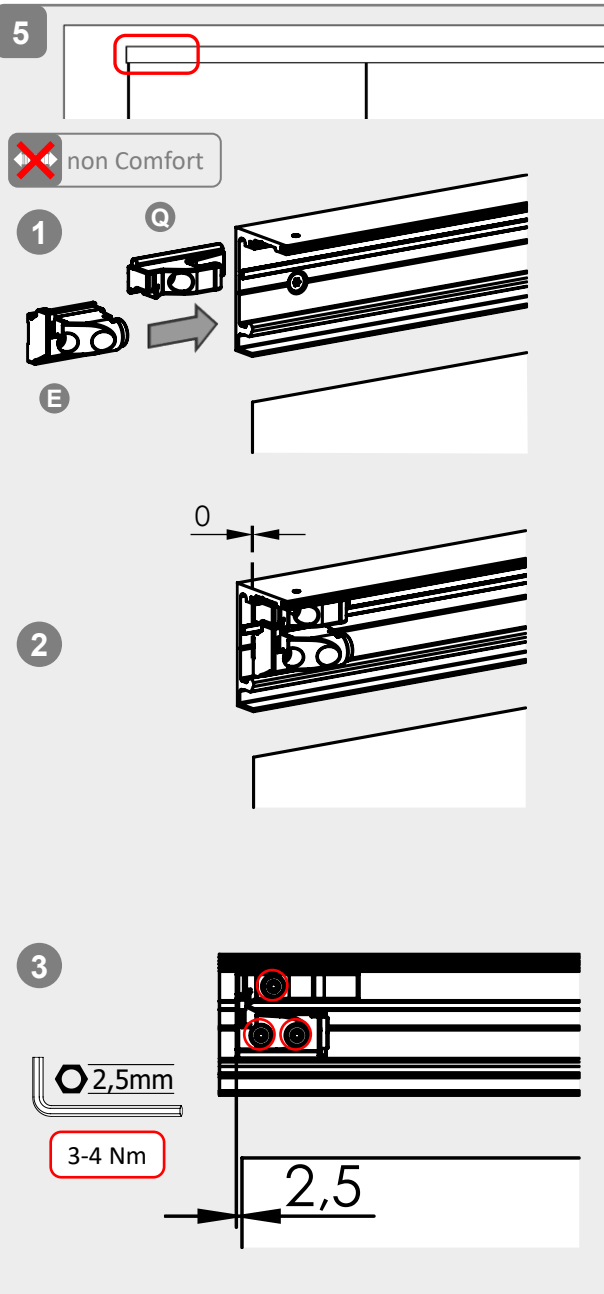
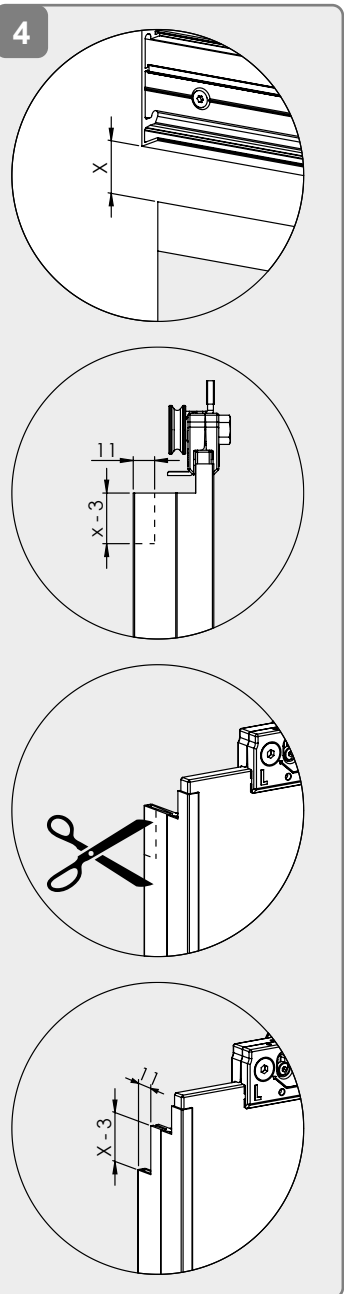

SCHIEBETÜRSYSTEM PLANEО X - AIR silent

6a

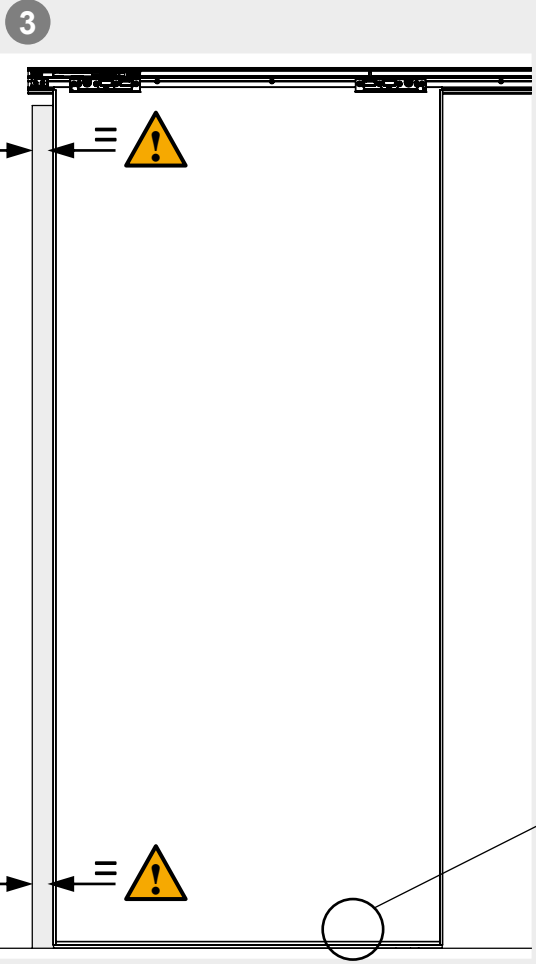
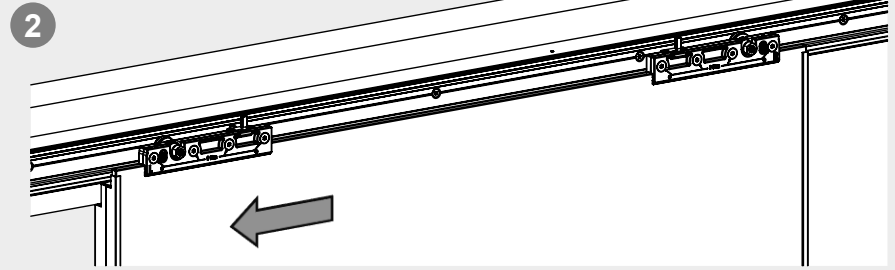
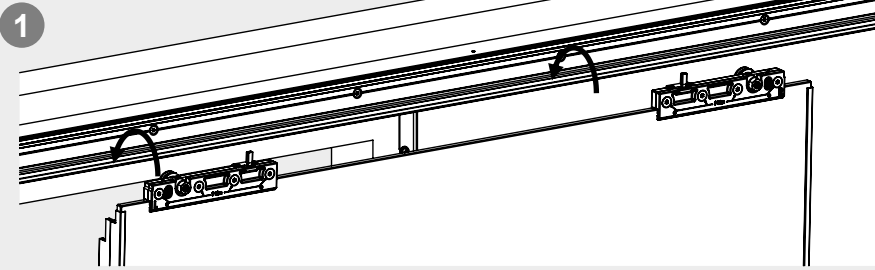

Dichtung an Laibungskante parallel ausrichten, Bürste sollte auf Fußboden aufliegen / align the seal parallel to the edge of the reveal, brush should rest on the floor

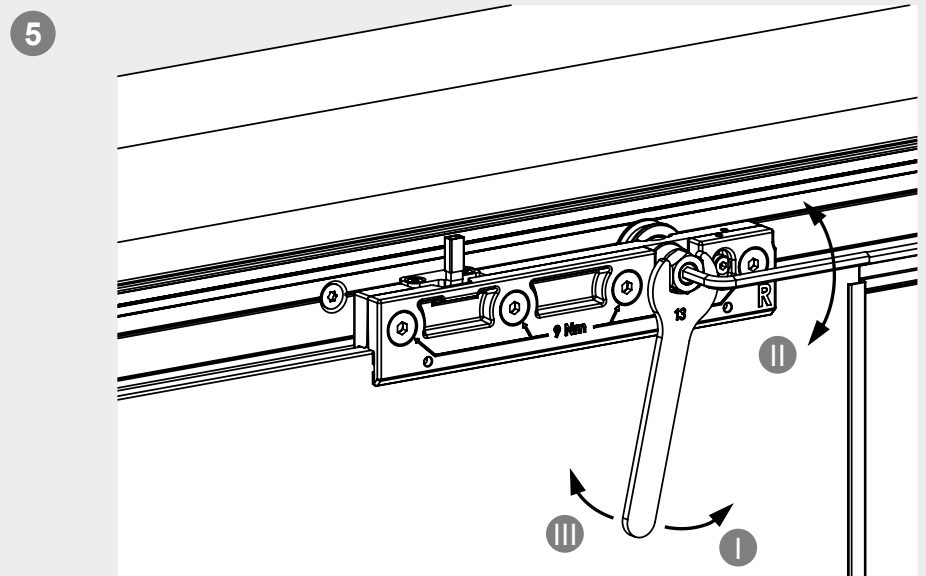
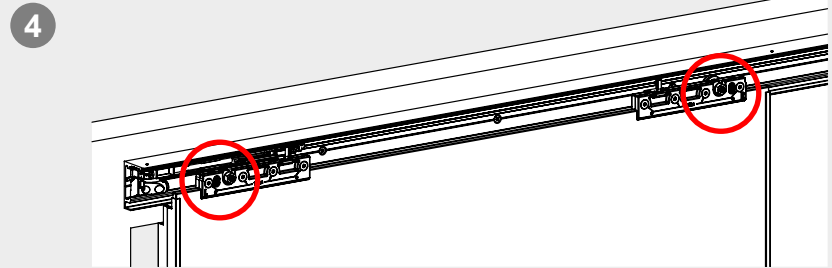

6b

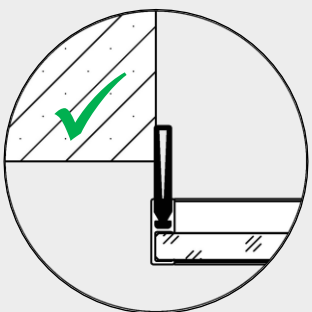
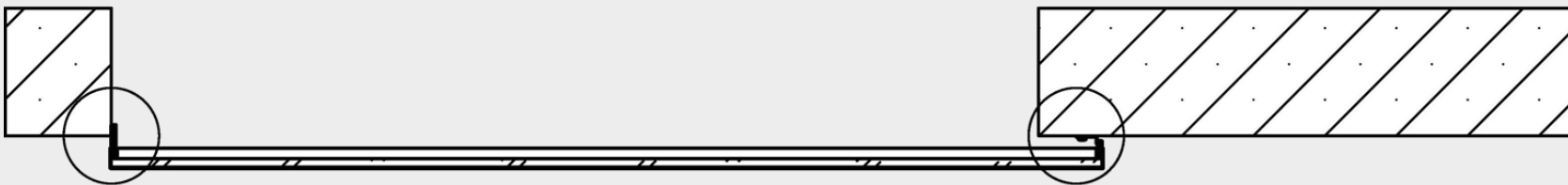

Türe perfekt eingestellt
door perfectly adjusted

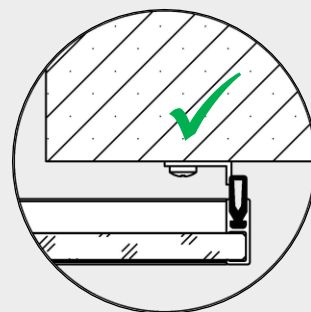
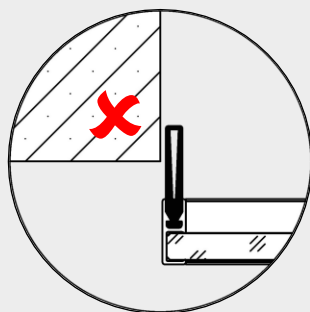

Anschlagleiste einstellen
adjust stop bar

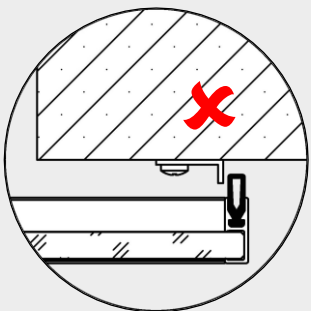
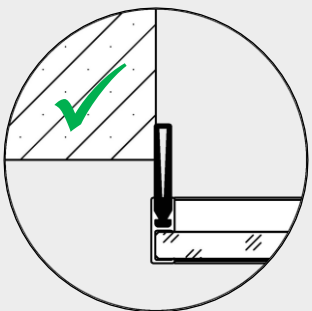
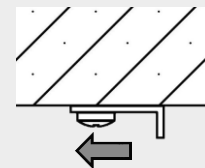

Anschlagleiste einstellen
adjust stop bar

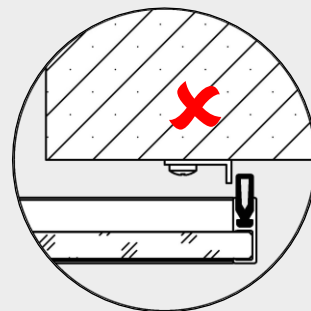
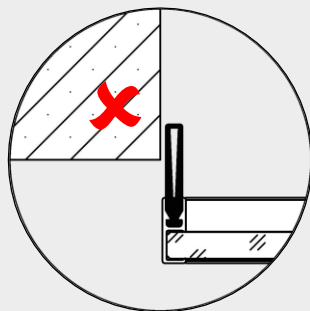
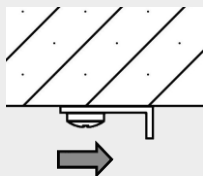

Endstopper und
Softeinzug einstellen
set end stopper and soft
close

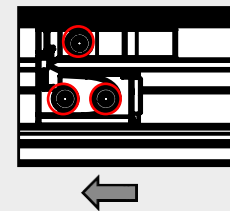

SCHIEBETÜRSYSTEM PLANEО X - AIR silent

7 Türe aushängen / unhook the door

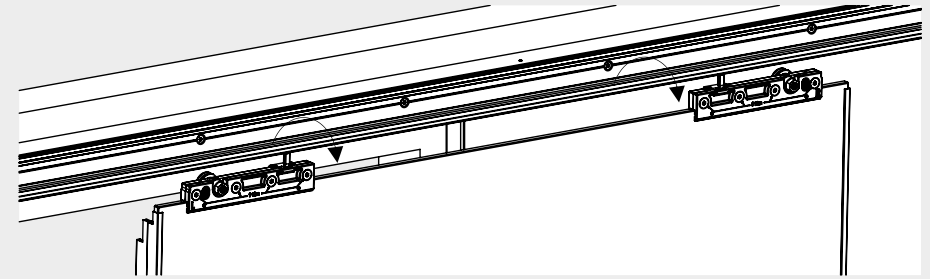
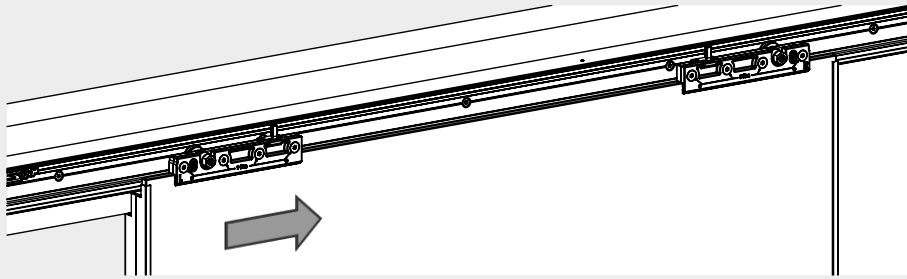

8

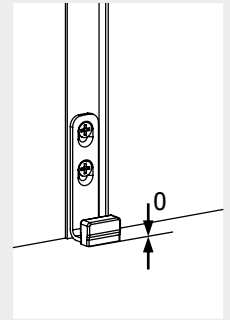
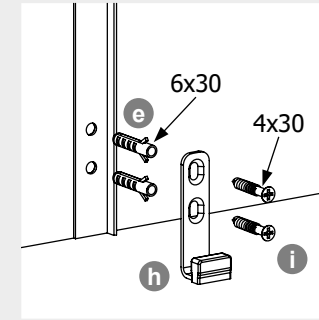
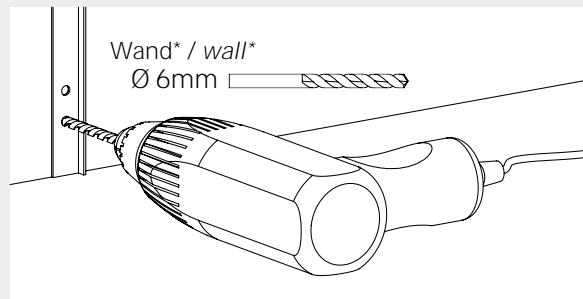
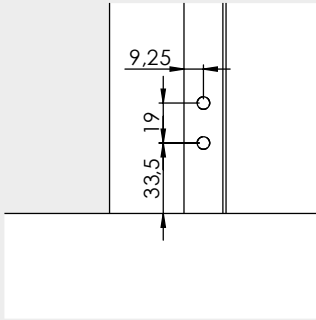
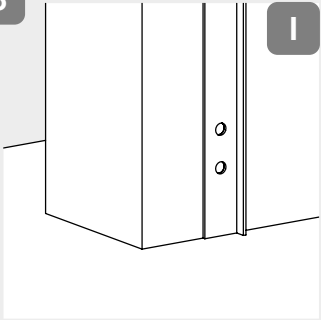

*Bohrer entsprechend Untergrund wählen / *select a drill according to the substrate

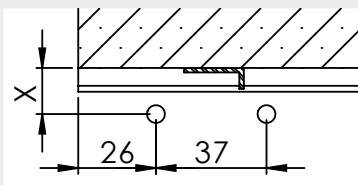
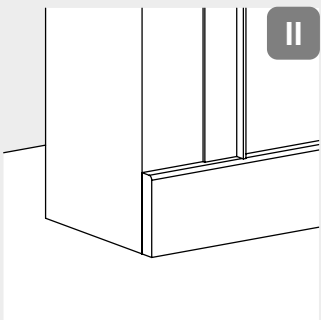

$X = 14,5\text{mm}$

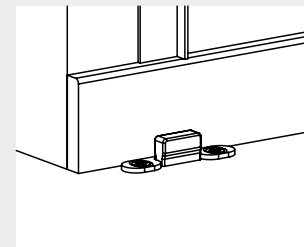
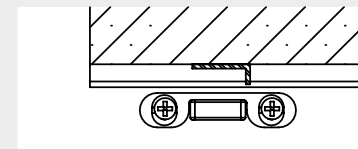
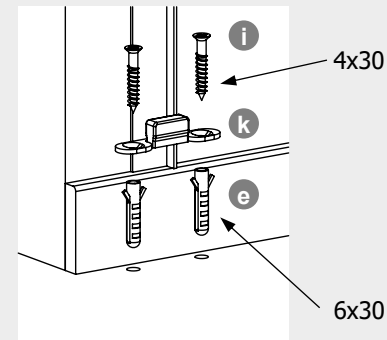
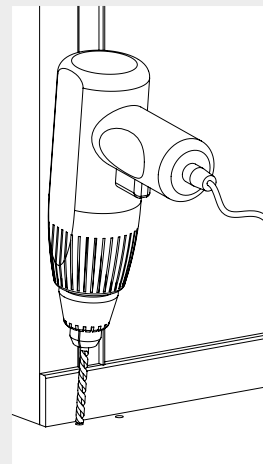

Ggf. zusätzlich das Maß des Abstandprofils addieren /
If necessary, add the dimension of the distance profile

*Bohrer entsprechend Untergrund wählen / *select a drill according to the substrate

9

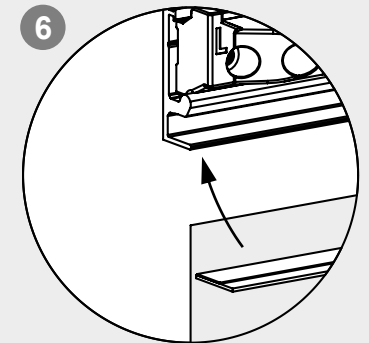
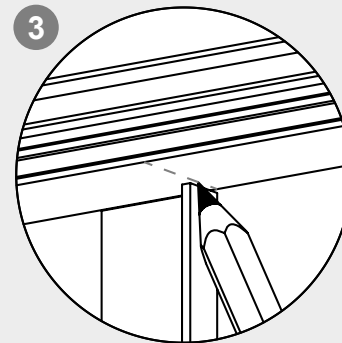
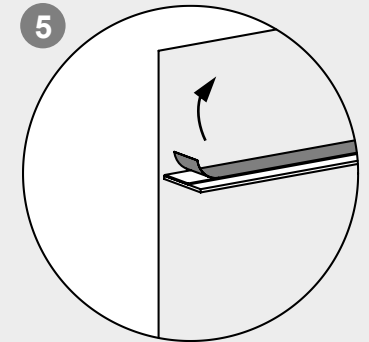
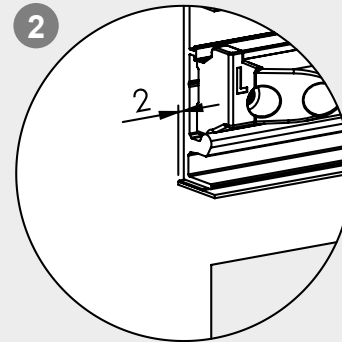
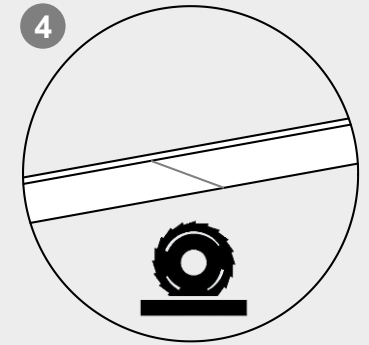
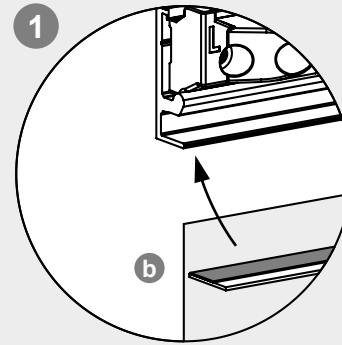
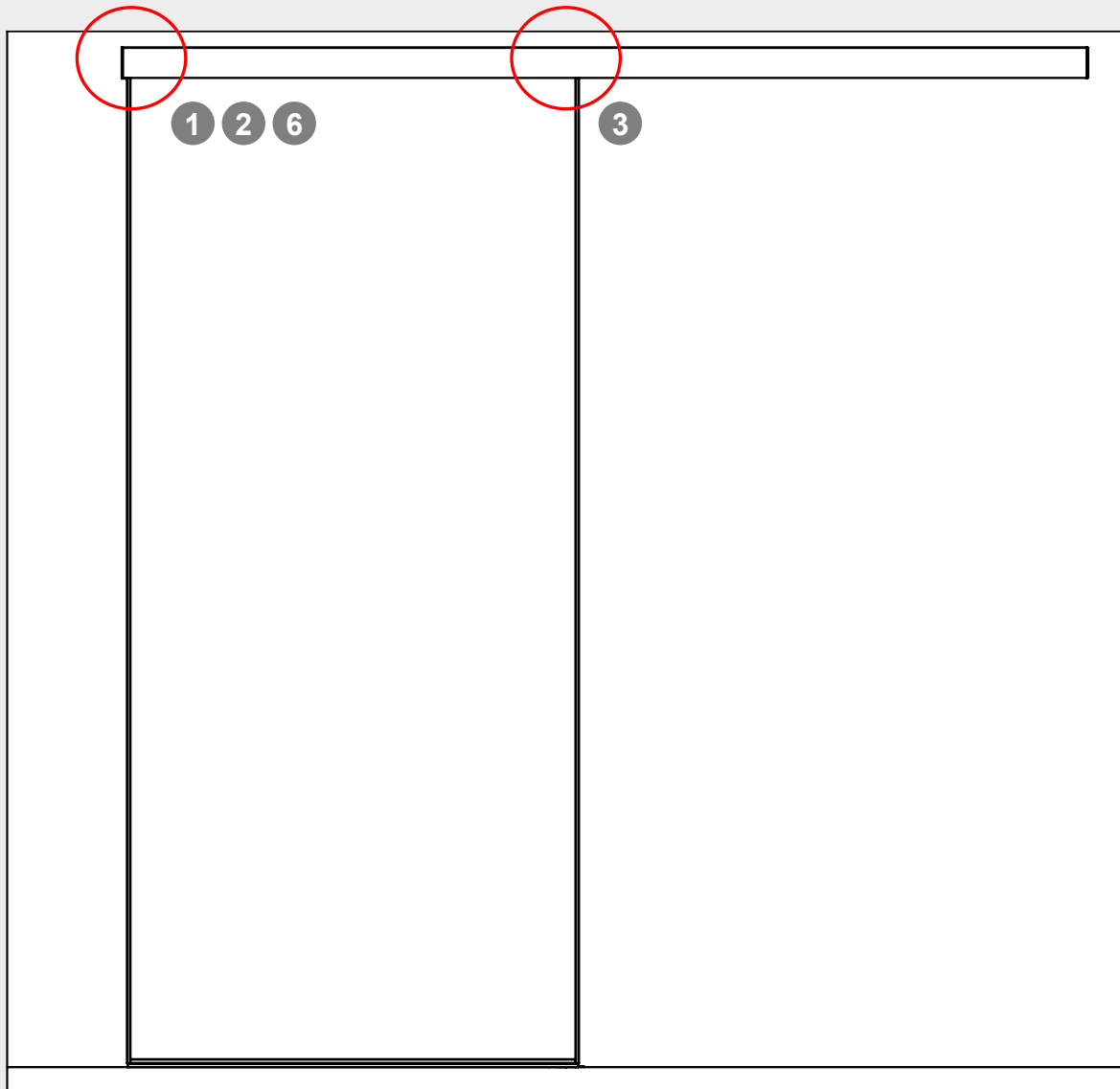

SCHIEBETÜRSYSTEM PLANEО X - AIR silent

10

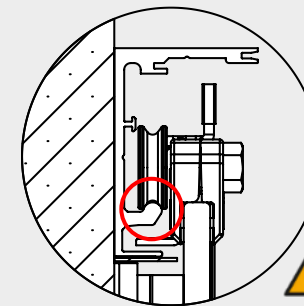
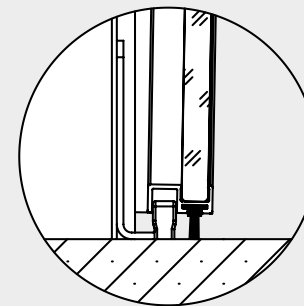
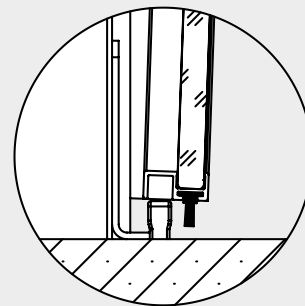
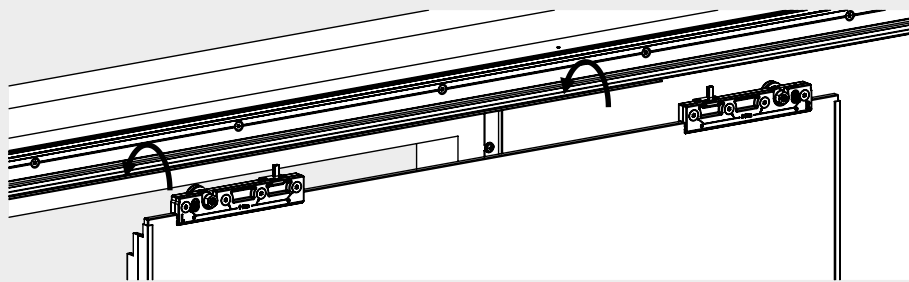

11a

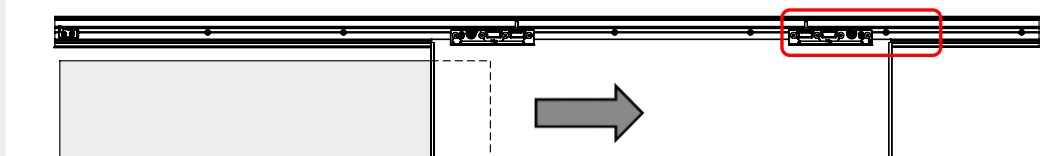

Ggf. Griffstangen/Griffmuscheln auf Innenseite berücksichtigen und Endposition der Tür entsprechend wählen!
 If applicable, keep pull handles/finger pulls inside in mind and choose endposition of door accordingly.

non Comfort

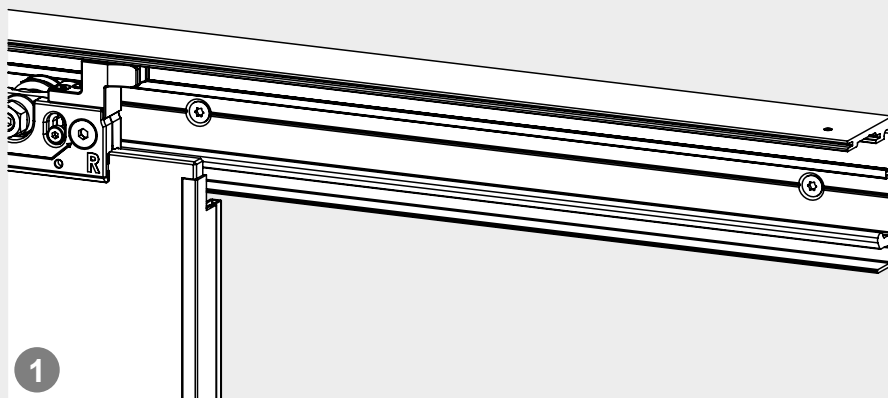

1

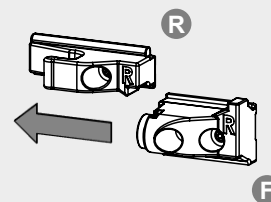

R

F

4-5 Nm



2,5mm

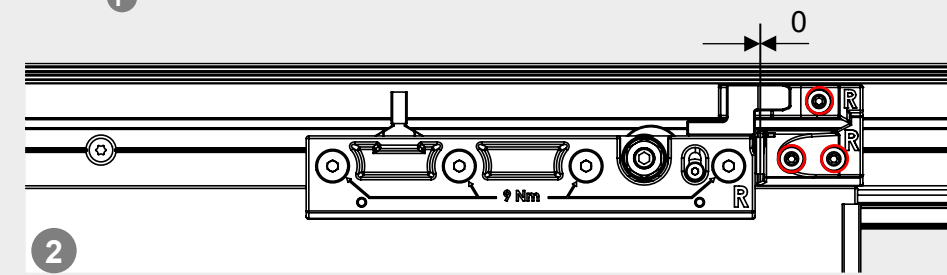

2

SCHIEBETÜRSYSTEM PLANEО X - AIR silent

11b

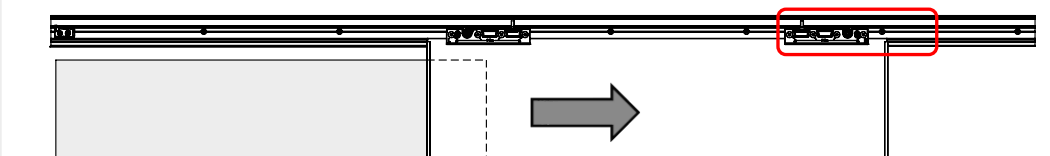

Ggf. Griffstangen/Griffmuscheln auf Innenseite berücksichtigen und Endposition der Tür entsprechend wählen!
If applicable, keep pull handles/finger pulls inside in mind and choose endposition of door accordingly.

←→ Comfort

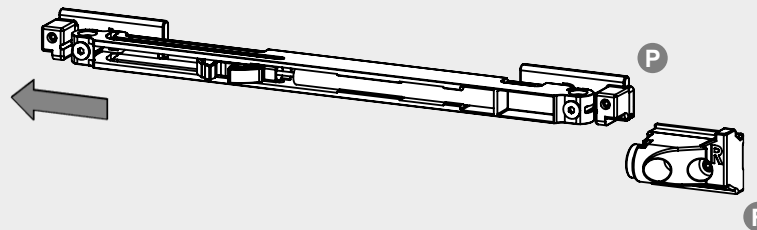
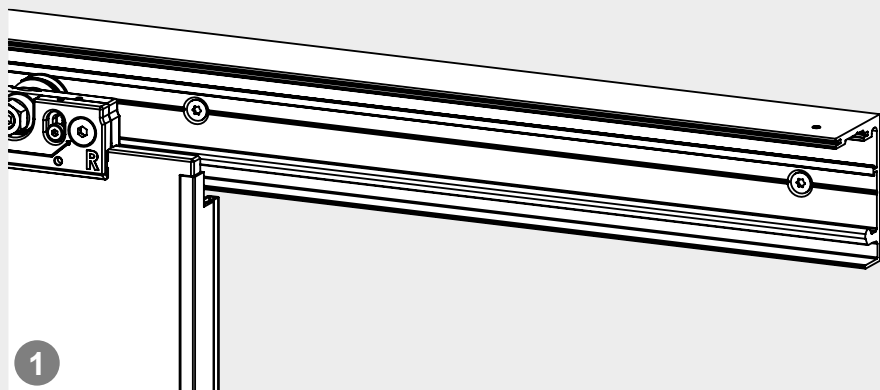

1

4-5 Nm



2,5mm

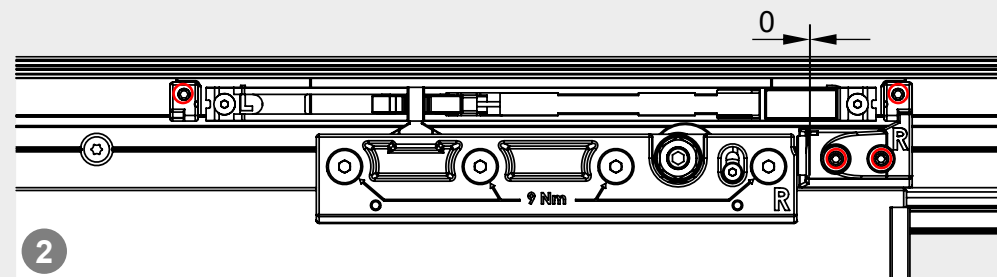

2

SCHIEBETÜRSYSTEM PLANEО X - AIR silent

12

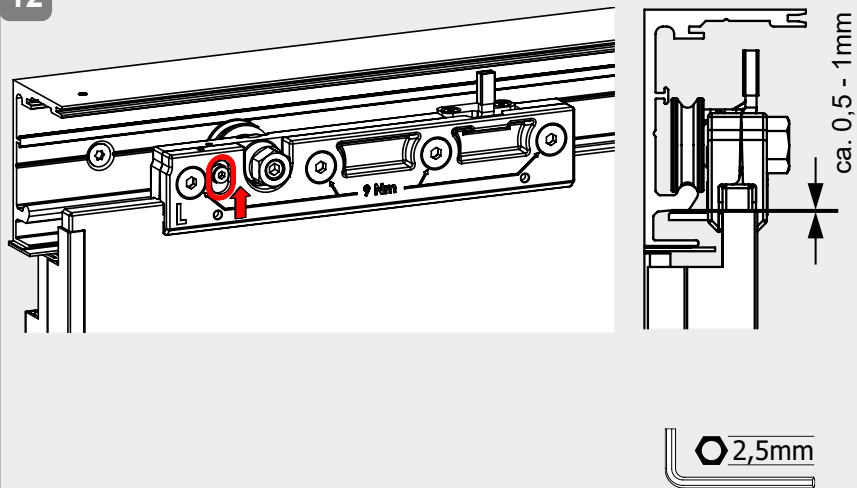

13

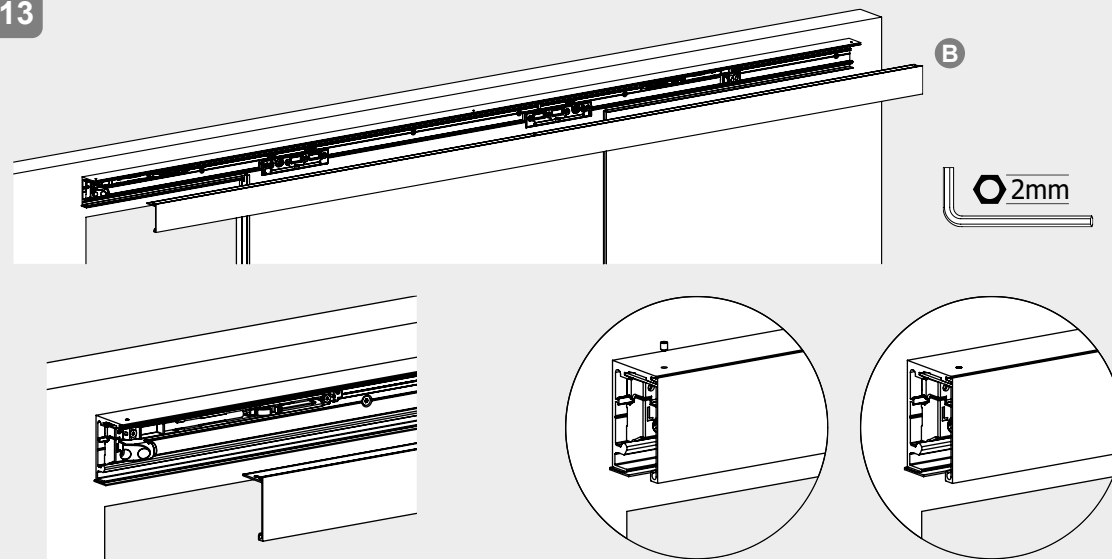

14

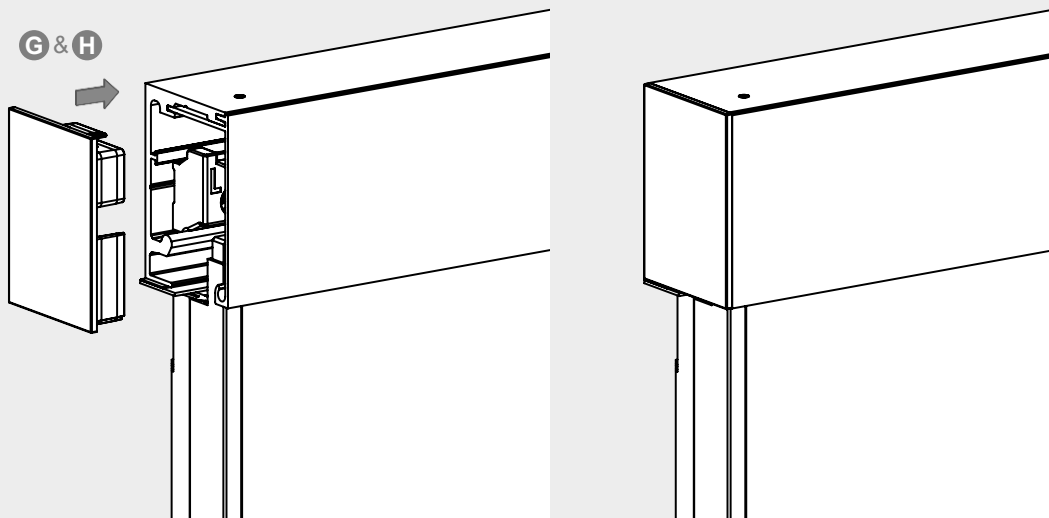

I

